



HU355STM
HU355CAT

HURRICANE headers.
HURRICANE cats.
Refer to HURRICANE catalogue for fitting details.
Gasket headers TG1020
Gasket headers to cats BEG474 x 2



HTH149
HTH149SS
HTH149HFC

HITECH headers.
HITECH headers stainless.
HITECH cats.
Refer to HITECH catalogue for fitting details.
Gasket headers TG1020
Gasket headers to cats BEG474 x 2



BS9592

PEX centre.
Pipe size 57mm and 76mm, chambered muffler design, fully flanged.
Bolts direct to original cats or to the above header and cat combinations.
Gasket inlet BEG297 x 2



BS9593

PEX rear.
Pipe size 57mm and 63mm, tuned muffler design, fully flanged.
Comes with stainless steel tips.
Gasket inlet BEG469



BS9565

PEX rear.
Pipe size 63mm, chambered muffler design, fully flanged.
Gasket inlet BEG469
Recommended tip BSX346 x 2
Note: This muffler is louder than BS9593, cabin droning will occur at certain speeds.

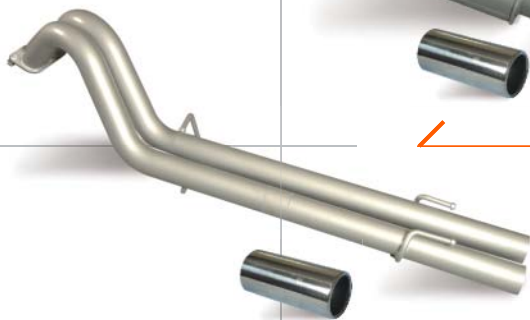

BS9596



PEX rear.
Pipe size 63mm, fully flanged.
Gasket inlet BEG469
Recommended tip BSX346 x 2
! Recommended for track or off road use only.